



PAKSOU

Product Catalogue

CONDENSING
BOILER

PAKSOU CONDENSING BOILER



Package and Condensing Boiler Series 400

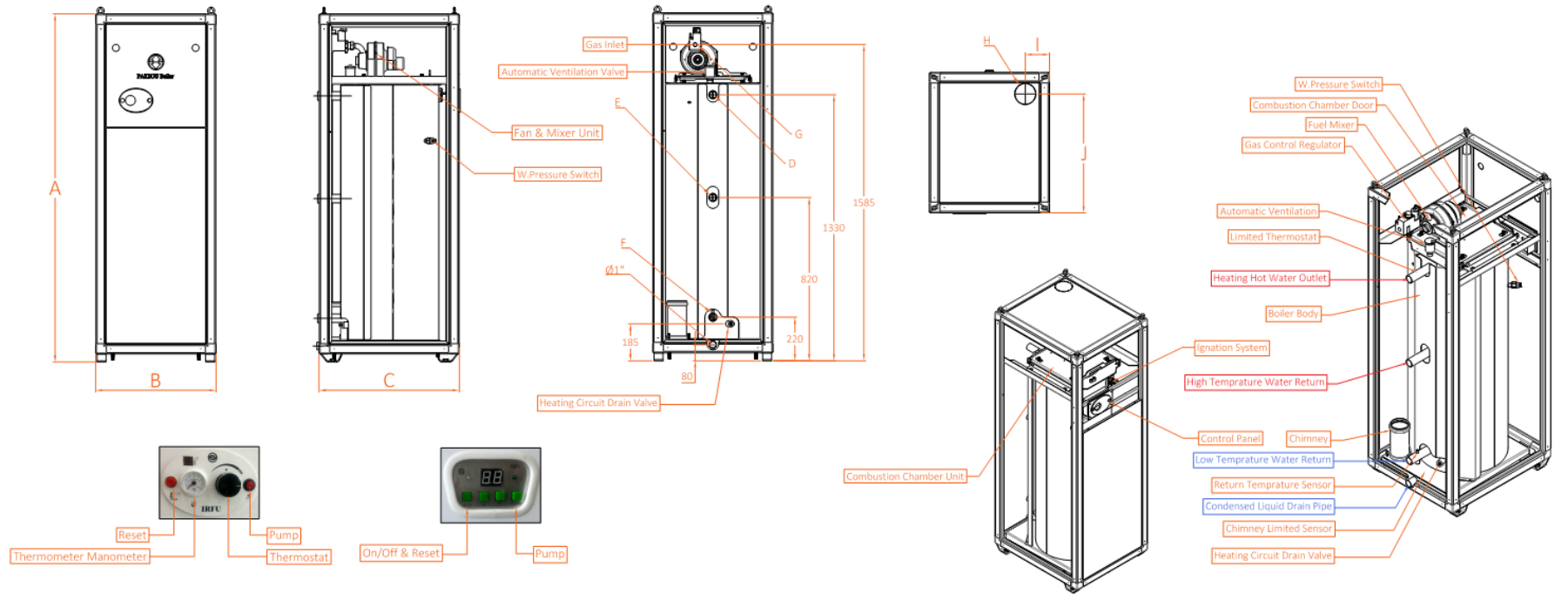

Features



- ❑ 18 Months Guarantee
- ❑ Equipped with Pre mix Burner
- ❑ The First Producer of package and Boiler with capacity from 70 to 320 KW in IRAN
- ❑ Low fuel consumption with 107% thermal efficiency
- ❑ The most powerful condensing package in IRAN
- ❑ According to the last technology in the world
- ❑ Ability to install cascade up to 20 devices (6400 KW just in one powerhouse)
- ❑ Stainless steel heat exchanger
- ❑ Small, Without noise, High dewatering volume, Low weight
- ❑ Quick installation and simple
- ❑ Equipped with control panel and hydraulic pressure and temperature safety sensors

Technology

Compatible with modern day technology and it is suitable replacement for common powerhouse with high volume, noisy, high costs and high fuel consumption. It is suitable for heating and hot water supply of residential buildings or public areas(hospitals, pools, banks, schools, hotels & etc...) from capacity of 70 to 320 KW. Due to its 107% thermal efficiency, it has very low fuel consumption and is environmentally friendly. The use of stainless steel heat exchanger, while extending its service life and mechanical strength, enables it to be operated up to 10 bar the operating pressure.

Dimensions for Installation Location according to Manufacturing Series												
Dim Parameter / Model	A	B	C	D	E	F	G	H	I	J	Capacity (liter)	Weight
407	1745	605	705	1,¼"	1,¼"	1,¼"	½"	80	120	600	160	212
412	1745	695	810	1,¼"	1,¼"	1,¼"	½"	100	120	695	265	282
422	1775	825	955	2"	2"	2"	1"	160	160	825	380	410
432	1800	945	1100	DN65 PN10	DN65 PN10	DN65 PN10	1"	200	160	950	530	540
443	1900	1115	1430	DN80 PN16	DN80 PN16	DN80 PN16	1,½"	250	250	1205	730	745

Package and Condensing Boiler Series 400

Specifications	Heating Power (50/30)°C			Thermal Efficiency %		Thermal Efficiency % (Partial load 30%)	Working Pressure	Consumption of Natural Gas	Max. Chimney Temperature
	Unit Model	(Kw)	(Kcal/hr)	(Btu/hr)	Max(50/30)°C	Max(80/60)°C	Max(50/30)°C	Bar	m ³ /hr
407	70	60,000	240,000	102	98.3	107	0.8-6	7	42
412	125	108,000	432,000	102	98.3	107	0.8-6	12	42
422	220	190,000	760,000	102	98.5	107	0.8-6	22	45
432	320	275,000	1,100,000	102	98.5	107	0.8-6	32	45
443	430	370,000	1,480,000	102	98.5	107	0.8 - 10	45.5	55

Combustion Chamber

Since the package and condensing boiler series 400 equipped with **PREMIX** Burner, that caused to full and uniform distribution of the heating load from inside of the combustion chamber and will protect the heat exchanger and mixer unit from the heating load. The combustion chamber occupies very little space vertically, as that the entire length of the heat exchanger can be exploited and This provides many advantages over liquid condensation and uniform heat distribution in the boiler.

Heat Exchanger

Heat Exchanger and fire Tubes of condensing boiler series 400 are stainless steel and special sectional of this tubes is caused to be increased the heat transfer surface. This Exchanger also has a high capacity of tank volume for dewatering and is designed and manufactured with the lowest amount of heat dissipation.